

SVS

SCALABLE VIDEO SWITCH



User Manual v2.1

Table of Contents

User Manual v2.1.....	1
Hardware Overview.....	3
Control Module:.....	3
SCART Input Module:.....	4
Component Input Module:.....	6
VGA Input Module:.....	7
Composite/S-Video Input Module:.....	9
SCART Output Module:.....	10
Component Output Module:.....	11
VGA Output Module:.....	12
Composite/S-Video Output Module:.....	13
First Boot:.....	15
Normal Operation.....	16
Manual Mode.....	16
Infrared Remote Transmitter Programming.....	17
Clearing IR Codes from an Input.....	18
Factory Reset.....	18
RetroTink 4k Integration.....	18

Hardware Overview

Control Module:

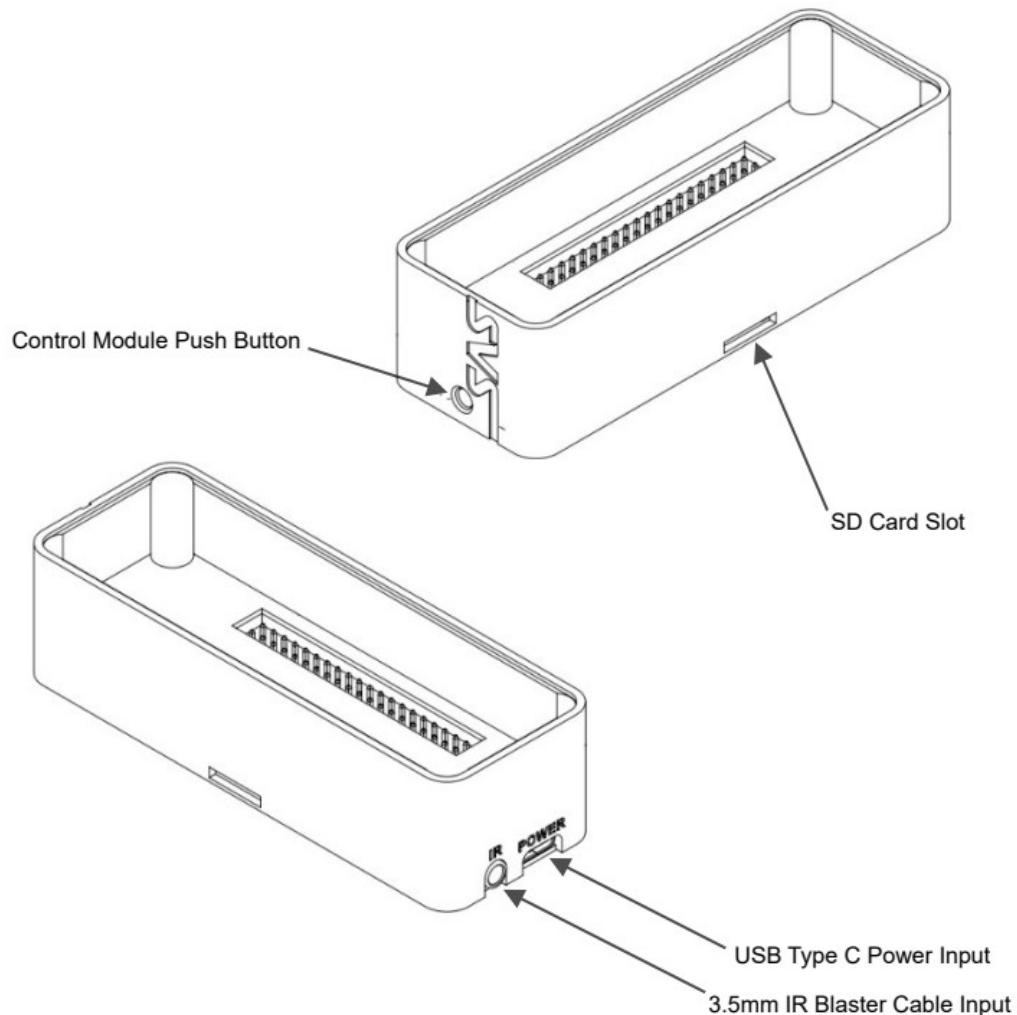

- 1. Control Module Push Button:** This button is used to control a variety of functions of your SVS. The primary function of the push button is to allow manual input switching. Pressing the control button during normal operation will cycle to the next input once per press. It is also used for special functions such as programming IR codes and performing factory resets as explained later in the guide.
- 2. SD Card Slot:** This slot can accommodate any Fat32 formatted SD card. The SD card is used to store various configuration files for SVS functions such as the IR blaster settings.
- 3. USB Type C Power Input:** This is the power input for the SVS, it requires a 1.5A +5v power supply with a USB Type C plug. This port can also be used to connect the SVS to your computer for firmware updates and serial communication.
- 4. 3.5mm IR Blaster Cable Input:** This is the port that your IR Blaster cable plugs into. This allows your SVS to transmit IR codes to other devices in your AV setup such as a scaler or TV.

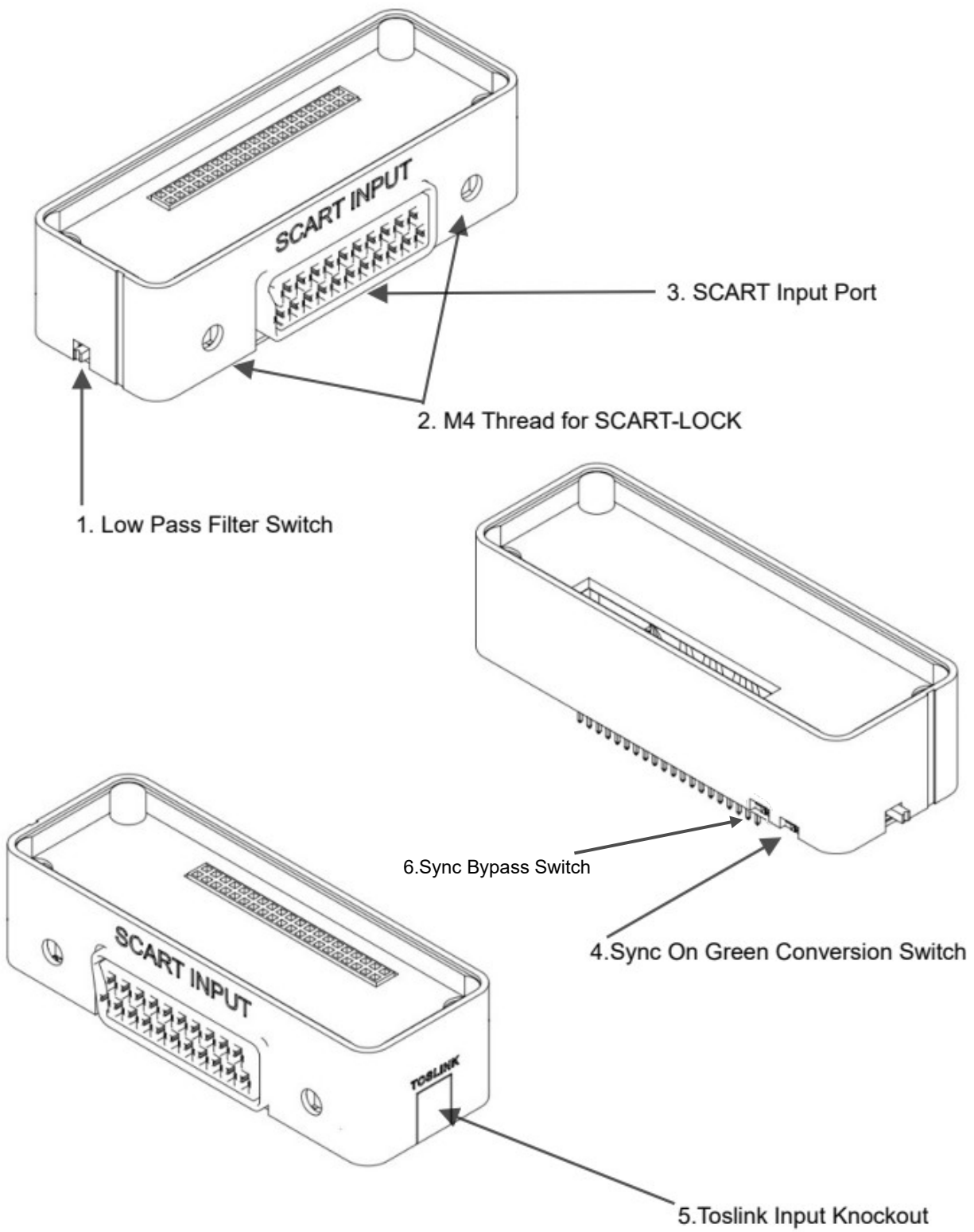

1. **Low Pass Filter Switch:** This switch controls the 9mhz low pass filter built into the module. The low pass filter is off when the switch is in the downward position away from the SCART input port. It is on when the switch is in the upward position toward the SCART input port. This filter should only be turned on for noisy 240p/480i sources, it will harm the image quality of high resolution inputs such as 480p and higher.
2. **M4 Thread for SCART-LOCK:** These threads are provided for use with the SCART-Lock accessory from Kytor Industries. This accessory allows you to securely mount your SCART cables without the risk of them coming loose.
3. **SCART Input Port:** This is the SCART input port for inputting audio and video to the SCART Input module. This input port can accept RGSB, RGSB and YPbPr signal types, and resolutions from 240p to 1080p.
4. **Sync On Green Conversion Switch:** This switch controls the sync on green conversion circuit inside the SCART Module. When the switch is in the forward position facing towards the front of the SCART input module sync on green conversion is off. This means RGSB sources will not be converted to RgsBS. When the switch is in the rearward position facing the rear of the SCART input module, sync on green conversion is on, which means all RGSB sources will be converted to RgsBS.
5. **Toslink Input Knockout:** This is a plastic tab that can be removed for any input that you plan to install a Toslink input module in. Removing this tab will leave an opening for the Toslink module to pass through. The tab can be removed by rocking it back and forth until the thin plastic surrounding it snaps loose
6. **Sync Bypass Switch:** This switch controls the Sync Bypass function of the V2 SCART Module. When the switch is in the forward position facing towards the front of the SCART input module sync bypass is off. This means the sync signal will be cleaned into pure Csync before being sent to the output modules. When the switch is in the rearward position facing the rear of the SCART input module, sync bypass is on, which means the sync signal will bypass all cleaning functions and be sent to the output modules as-is. This would allow composite video or S-Video to be input through the SCART module.

Component Input Module:

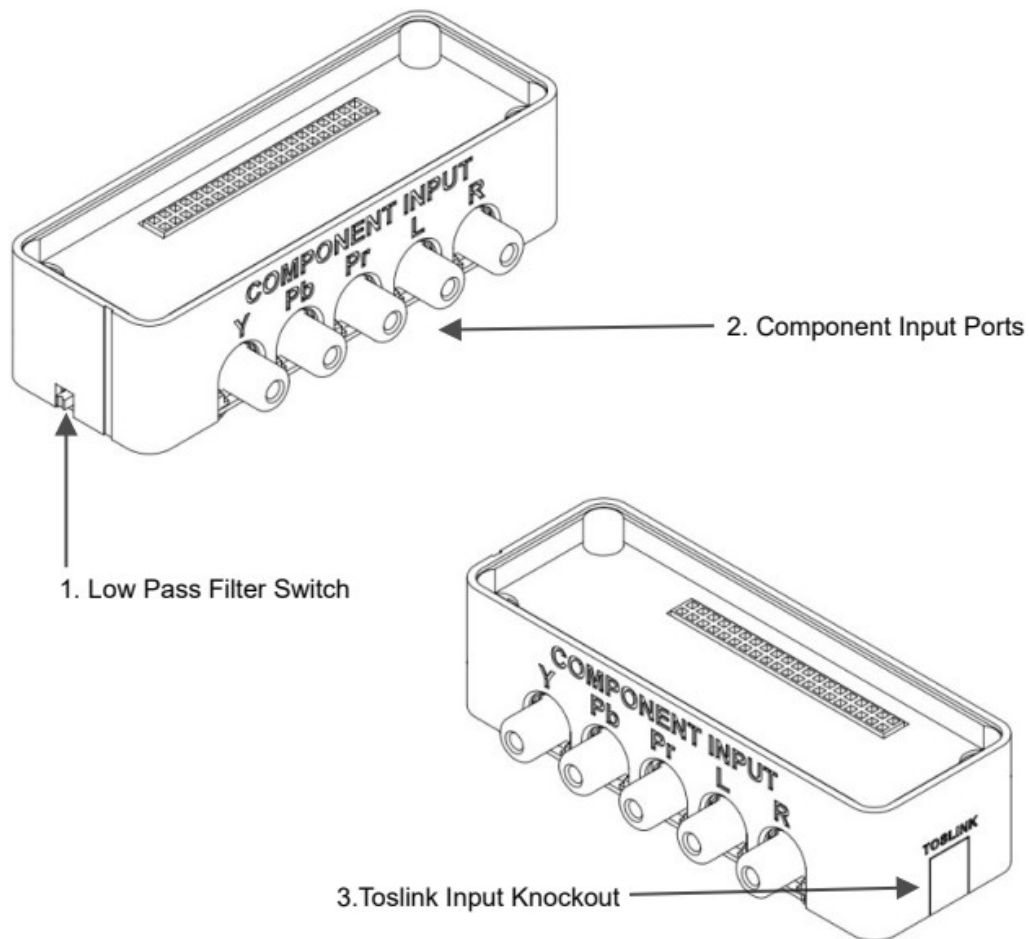

- 1. Low Pass Filter Switch:** This switch controls the 9mhz low pass filter built into the module. The low pass filter is off when the switch is in the downward position away from the Component input ports. It is on when the switch is in the upward position toward the Component input ports. This filter should only be turned on for noisy 240p/480i sources, it will harm the image quality of high resolution inputs such as 480p and higher..
- 2. Component Input Ports:** This is the Component input port for inputting audio and video to the Component Input module. These input ports can accept YPbPr, RGB, S-Video (Y/C on Green/Red) and Composite (CVBS on Green) signal types, and resolutions from 240p to 1080p.
- 3. Toslink Input Knockout:** This is a plastic tab that can be removed for any input that you plan to install a Toslink input module in. Removing this tab will leave an opening for the Toslink module to pass through. The tab can be removed by rocking it back and forth until the thin plastic surrounding it snaps loose.

VGA Input Module:

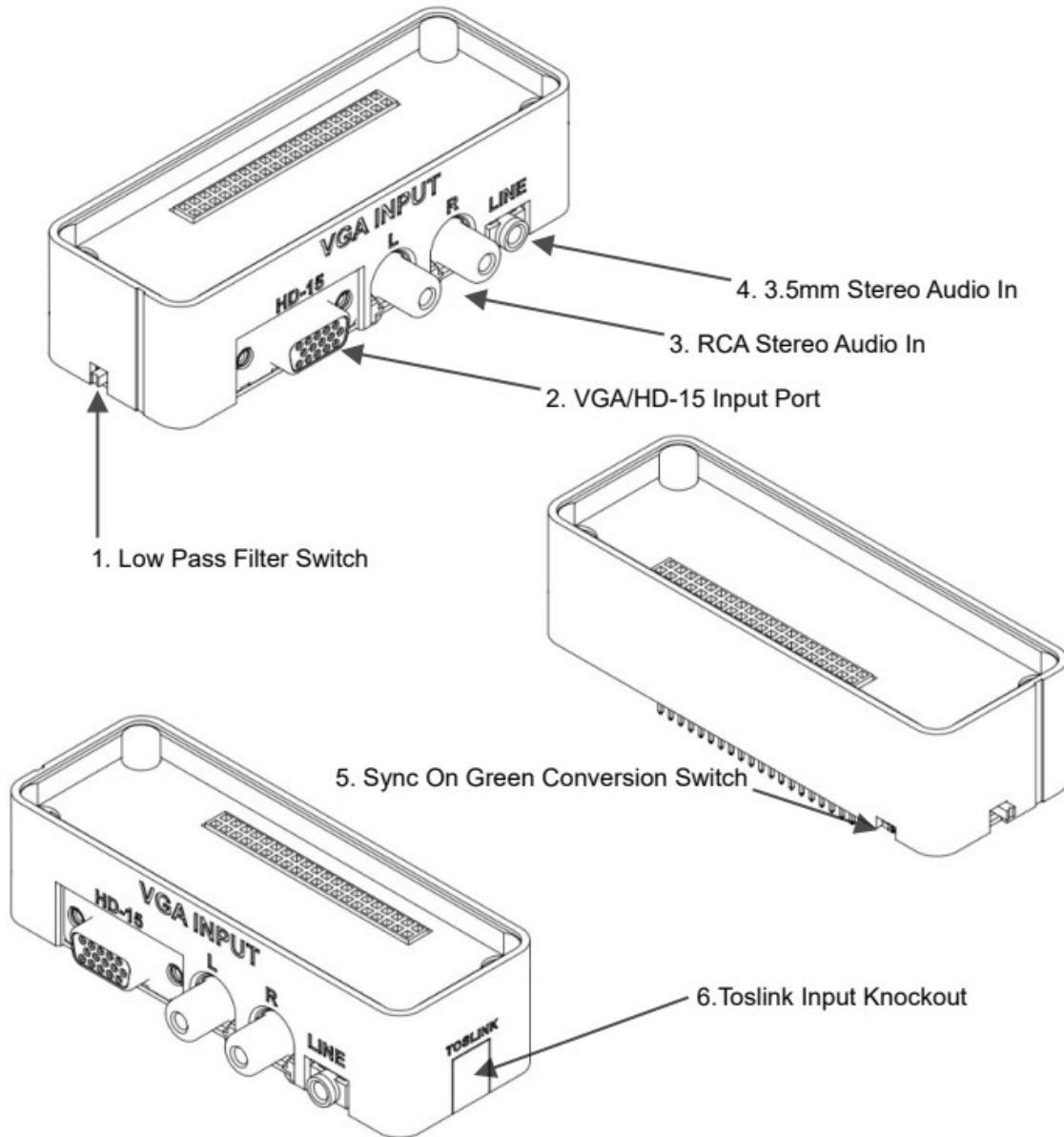

- 1. Low Pass Filter Switch:** This switch controls the 9mhz low pass filter built into the module. The low pass filter is off when the switch is in the downward position away from the VGA input port. It is on when the switch is in the upward position toward the VGA input port. This filter should only be turned on for noisy 240p/480i sources, it will harm the image quality of high resolution inputs such as 480p and higher.
- 2. VGA Input Port:** This is the VGA input port for inputting video to the VGA Input module. This input port can accept RGBHV and RGBS signal types, and resolutions from 240p to 1080p.

3. **RCA Stereo Audio Input:** This is one of the audio input options for the VGA input module. This input is a standard L/R RCA stereo input.
4. **3.5mm Stereo Audio Input:** This is one of the audio input options for the VGA input module. This input is a standard L/R 3.5mm TRS stereo input. This is a switched TRS jack, so if an audio input is plugged into this jack the RCA Stereo Input is disabled.
5. **Sync On Green Conversion Switch:** This switch controls the sync on green conversion circuit inside the VGA Module. When the switch is in the forward position facing towards the front of the VGA input module sync on green conversion is off. This means RGBHV/RGBS sources will not be converted to RGsBS. When the switch is in the rearward position facing the rear of the VGA input module, sync on green conversion is on, which means all RGBHV/RGBS sources will be converted to RGsBS.
6. **Toslink Input Knockout:** This is a plastic tab that can be removed for any input that you plan to install a Toslink input module in. Removing this tab will leave an opening for the Toslink module to pass through. The tab can be removed by rocking it back and forth until the thin plastic surrounding it snaps loose.

Composite/S-Video Input Module:

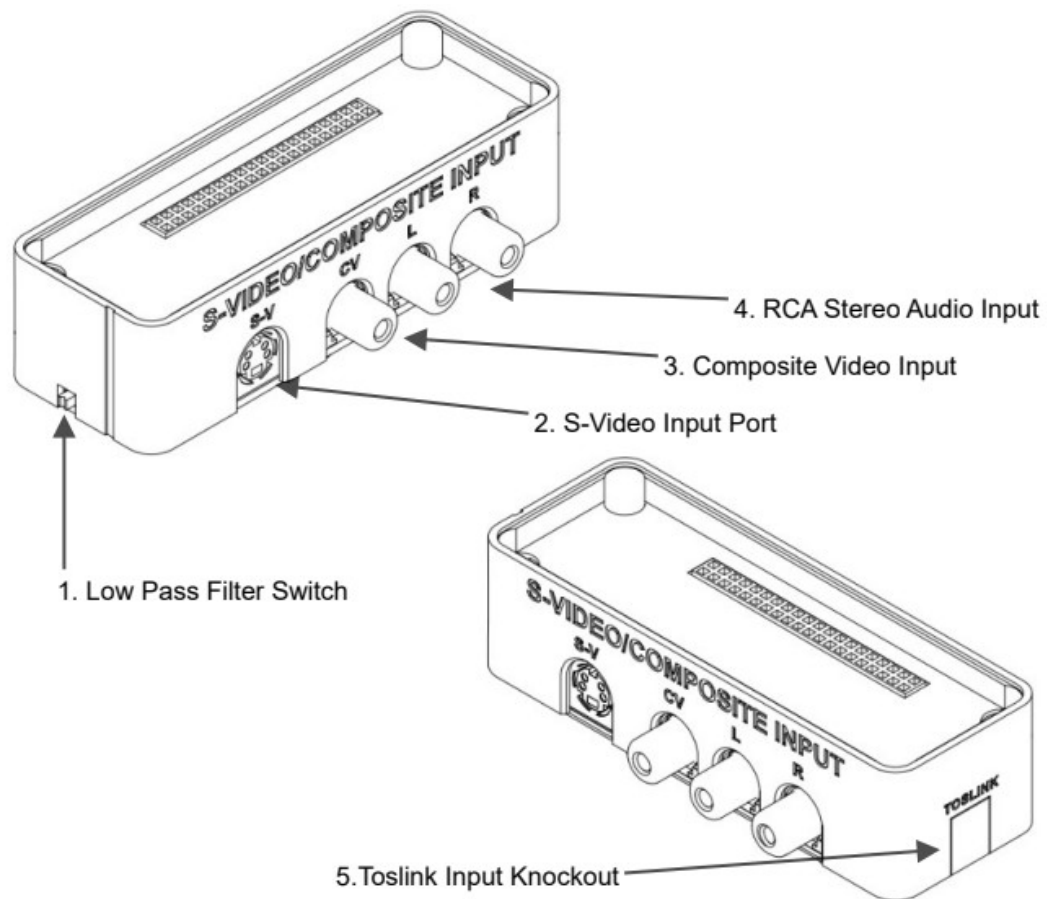

- 1. Low Pass Filter Switch:** This switch controls the 9mhz low pass filter built into the module. The low pass filter is off when the switch is in the downward position away from the Composite/S-Video input port. It is on when the switch is in the upward position toward the Composite/S-Video input ports. This filter should only be turned on for noisy 240p/480i sources.
- 2. S-Video Input Port:** This is the S-Video input port for inputting video to the Composite/S-Video Input module. This input port can accept S-Video signal and resolutions from 240p to 480i.
- 3. Composite Input Port:** This is the Composite input port for inputting video to the Composite/S-Video Input module. This input port can accept Composite signal and resolutions from 240p to 480i.
- 4. RCA Stereo Audio Input:** This is one of the audio input options for the Composite/S-Video input module. This input is a standard Left/Right RCA stereo input.
- 5. Toslink Input Knockout:** This is a plastic tab that can be removed for any input that you plan to install a Toslink input module in. Removing this tab will leave an opening for the Toslink module to pass through. The tab can be removed by rocking it back and forth until the thin plastic surrounding it snaps loose.

SCART Output Module:

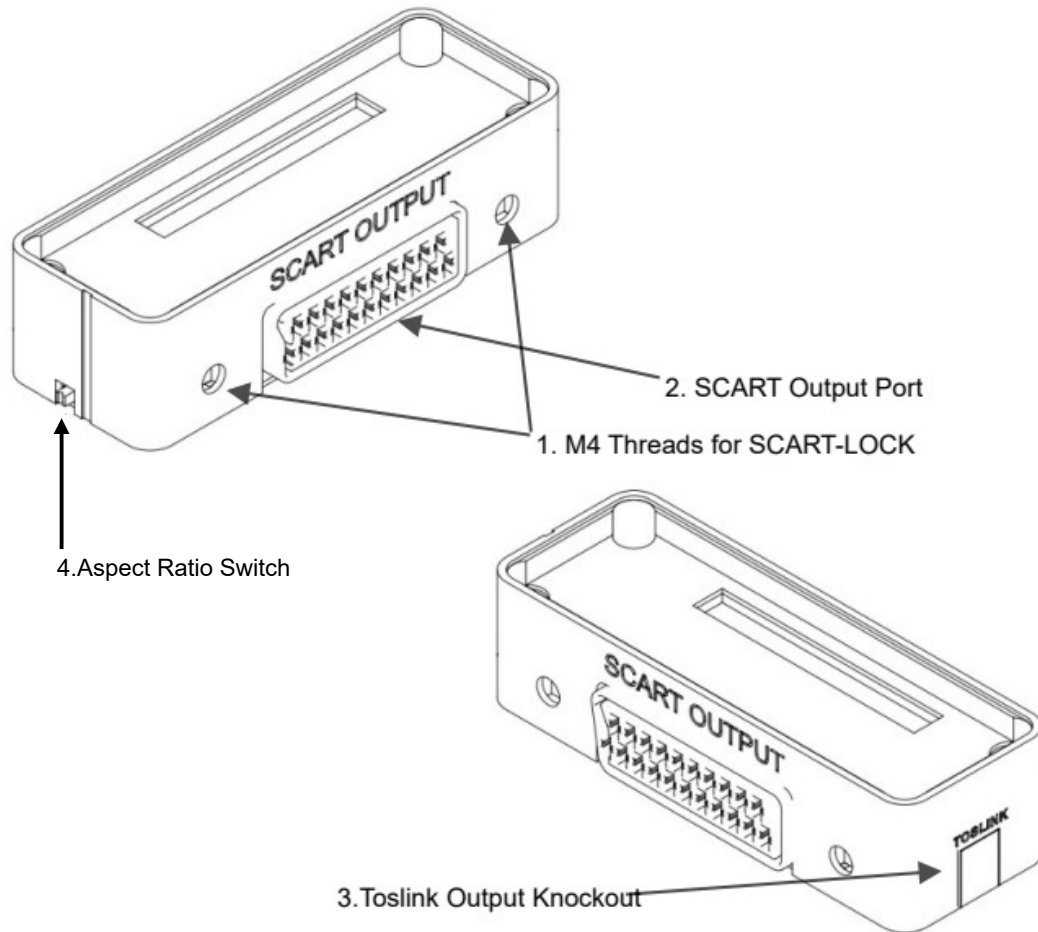

- 1. M4 Thread for SCART-LOCK:** These threads are provided for use with the SCART-Lock accessory from Kytor Industries. This accessory allows you to securely mount your SCART cables without the risk of them coming loose.
- 2. SCART Output Port:** This is the SCART Output port for outputting audio and video from the SCART output module. This output port can output RGBS, RGsB, YPbPr, S-Video (Y/C on Sync/Red) and Composite Video (CVBS on Sync) signal types, and resolutions from 240p to 1080p.
- 3. Toslink Output Knockout:** This is a plastic tab that can be removed for any input that you plan to install a Toslink Output module in. Removing this tab will leave an opening for the Toslink module to pass through. The tab can be removed by rocking it back and forth until the thin plastic surrounding it snaps loose.
- 4. Aspect Ratio Switch:** This switch changes the SCART Aspect ratio voltage level. In the down position the aspect ratio voltage is 12v for 4:3, in the up position the aspect ratio voltage is 5v for 16:9.

Component Output Module:

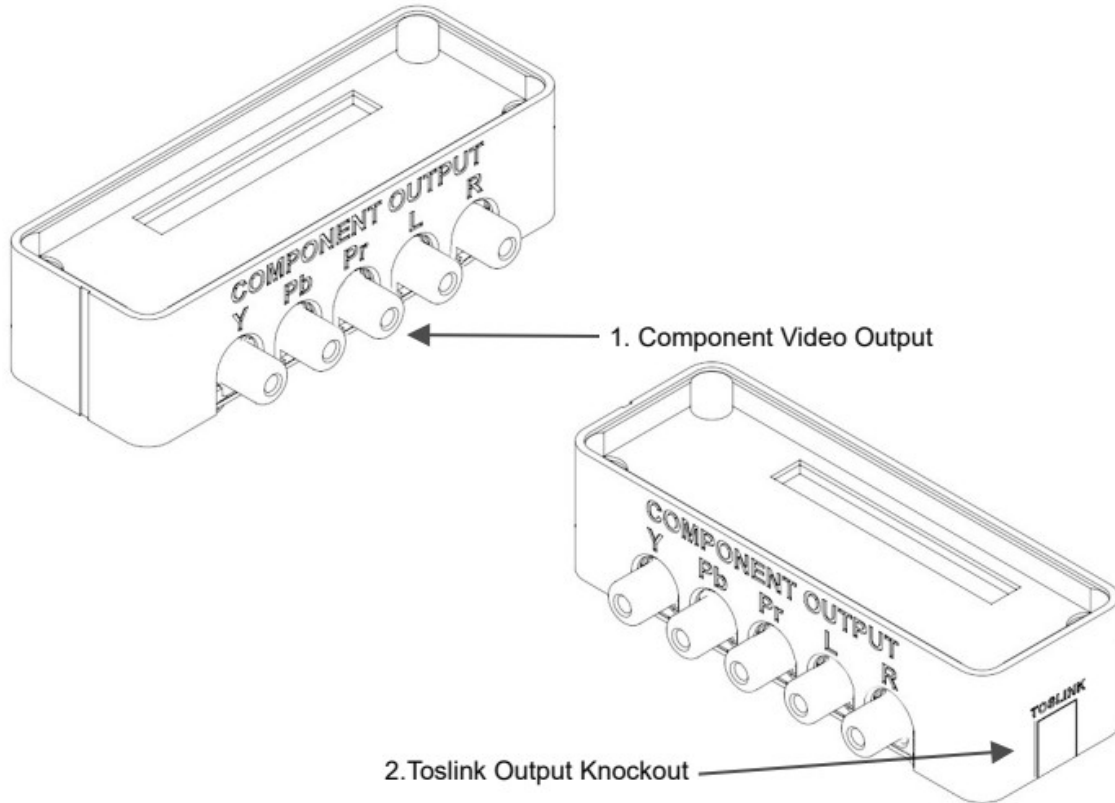

- 1. Component Output Port:** This is the Component Output port for outputting audio and video from the Component output module. This output port can output RGB, YPbPr, S-Video (Y/C on Green/Red) and Composite Video (CVBS on Green) signal types, and resolutions from 240p to 1080p.
- 2. Toslink Output Knockout:** This is a plastic tab that can be removed for any input that you plan to install a Toslink output module in. Removing this tab will leave an opening for the Toslink module to pass through. The tab can be removed by rocking it back and forth until the thin plastic surrounding it snaps loose.

VGA Output Module:

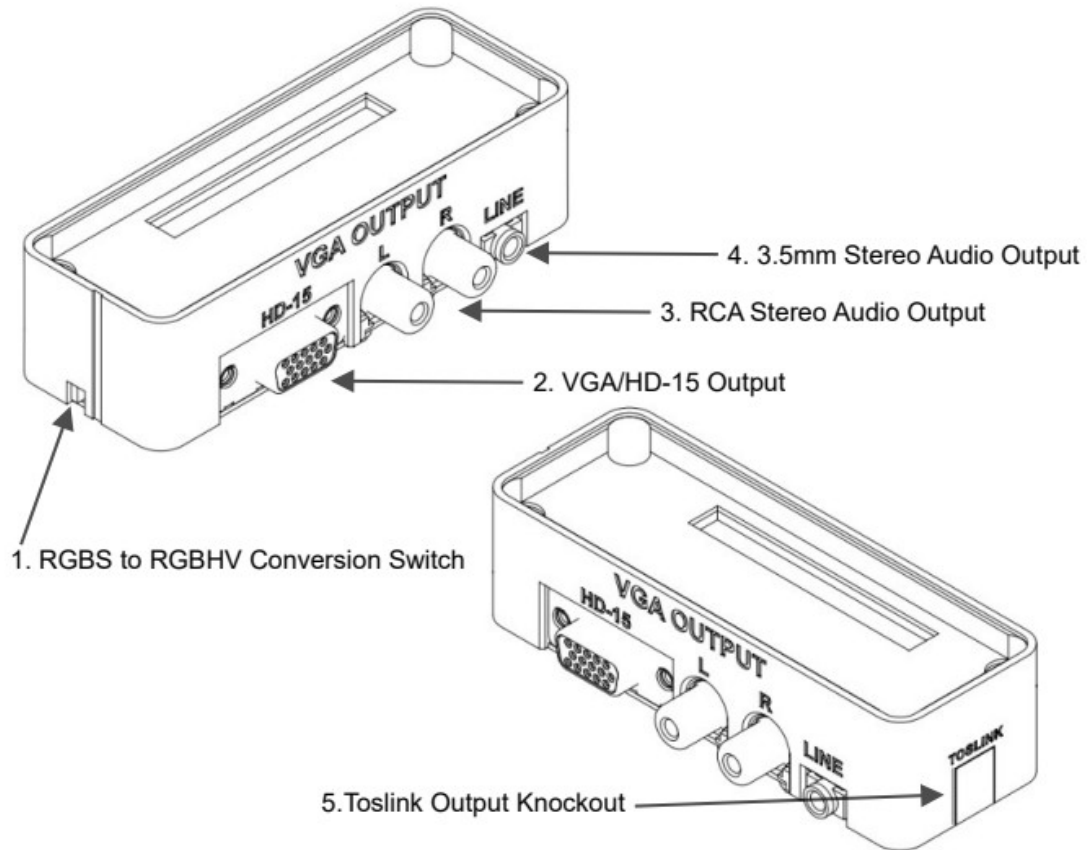

- 1. RGBS to RGBHV Conversion Switch:** This switch controls the RGBS to RGBHV conversion circuit inside the VGA Output module. If this switch is in the downward position the RGBS to RGBHV conversion is on. This means any RGBS input will be converted to RGBHV. If the switch is in the upward position then RGBS inputs will not be converted to RGBHV, C-Sync will be output on the H-Sync pin and nothing will be output on the V-Sync pin.
- 2. VGA Output Port:** This is the VGA Output port for outputting video from the VGA output module. This output port can output RGBHV, RGsB, YPbPr, S-Video (Y/C on Green/Red) and Composite Video (CVBS on Green) signal types, and resolutions from 240p to 1080p.
- 3. RCA Stereo Audio Output:** This is one of the audio output options for the VGA output module. This output is a standard Left/Right RCA stereo output.
- 4. 3.5mm Stereo Audio Output:** This is one of the audio output options for the VGA output module. This output is a standard Left/Right 3.5mm TRS stereo output. This is a switched TRS jack, so if an audio output is plugged into this jack the RCA Stereo output is disabled.
- 5. Toslink Output Knockout:** This is a plastic tab that can be removed for any input that you plan to install a Toslink output module in. Removing this tab will leave an opening for the Toslink module to pass through. The tab can be removed by rocking it back and forth until the thin plastic surrounding it snaps loose.

Composite/S-Video Output Module:

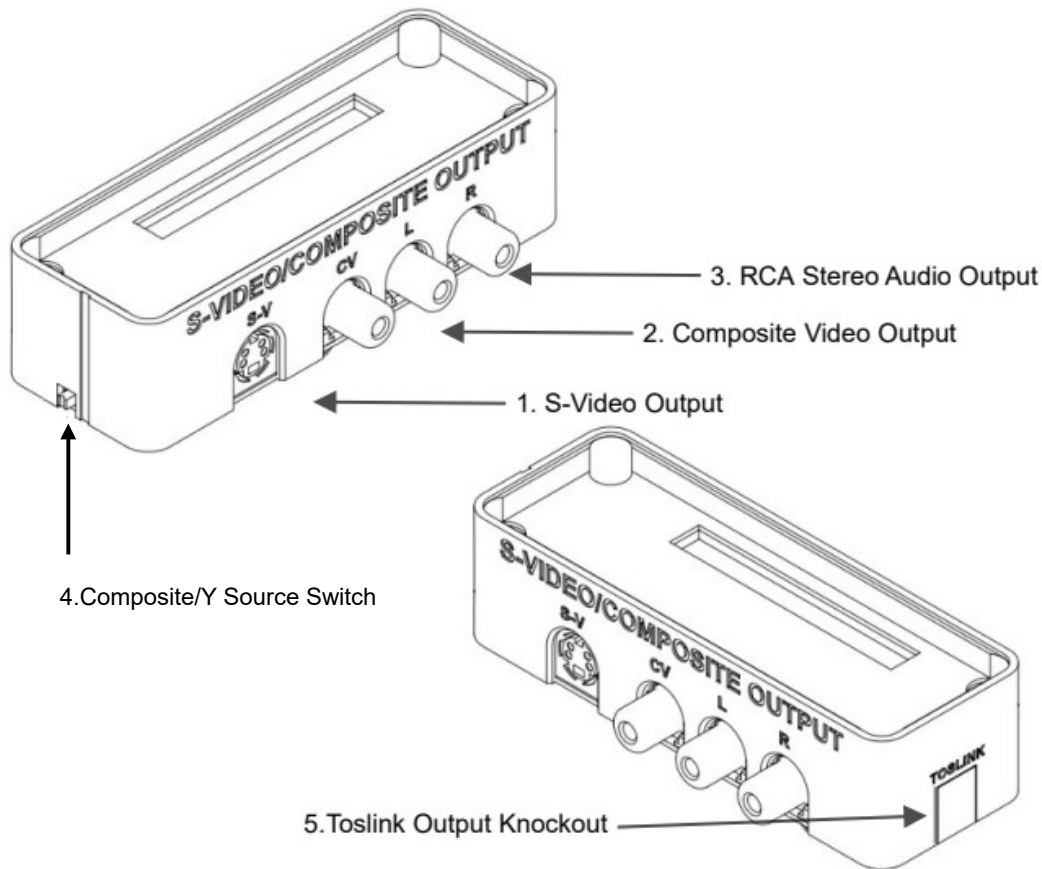

- 1. S-Video Output Port:** This is the S-Video output port for outputting video from the Composite/S-Video output module. This output port can output S-Video signal and resolutions from 240p to 480i.
- 2. Composite Output Port:** This is the Composite output port for outputting video from the Composite/S-Video output module. This output port can output Composite signal and resolutions from 240p to 480i.
- 3. RCA Stereo Audio Output:** This is one of the audio output options for the Composite/S-Video output module. This output is a standard Left/Right RCA stereo output.
- 4. Composite/Y Source Switch:** This switch determines which channel of the SVS is used for Composite/Y signals. In the down position the Sync channel is used for Composite/Y signals, in the up position the Green channel is used for Composite/Y signals. If you are using a Component input module to input Composite video you will need to put this switch in the up position for green, if you are using a SCART input module for to input Composite then place this switch in the down position for sync. If you are using a Composite/S-Video input to input composite then both switch positions will work equally well.
- 5. Toslink Output Knockout:** This is a plastic tab that can be removed for any input that you plan to install a Toslink output module in. Removing this tab will leave an opening for the Toslink module to pass through. The tab can be removed by rocking it back and forth until the thin plastic surrounding it snaps loose.

YPbPr to RGB and RGB to YPbPr Transcoder Modules:

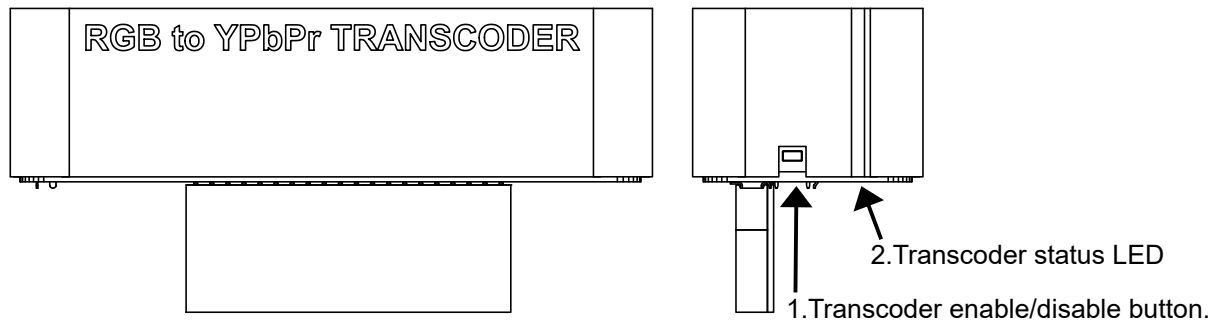

The YPbPr to RGB and RGB to YPbPr Transcoders can be configured to be enabled or disabled automatically for each individual input. The pushbutton on the front of the module toggles the transcoder between enabled and disabled. When the transcoder is enabled the blue status LED on the front of the module will be lit, when the transcoder is disabled the blue status LED will not be lit. To enable or disable the transcoder for a specific input, simply manually switch to that input, then press the button on the transcoder to enable or disable transcoding as needed.

First Boot:

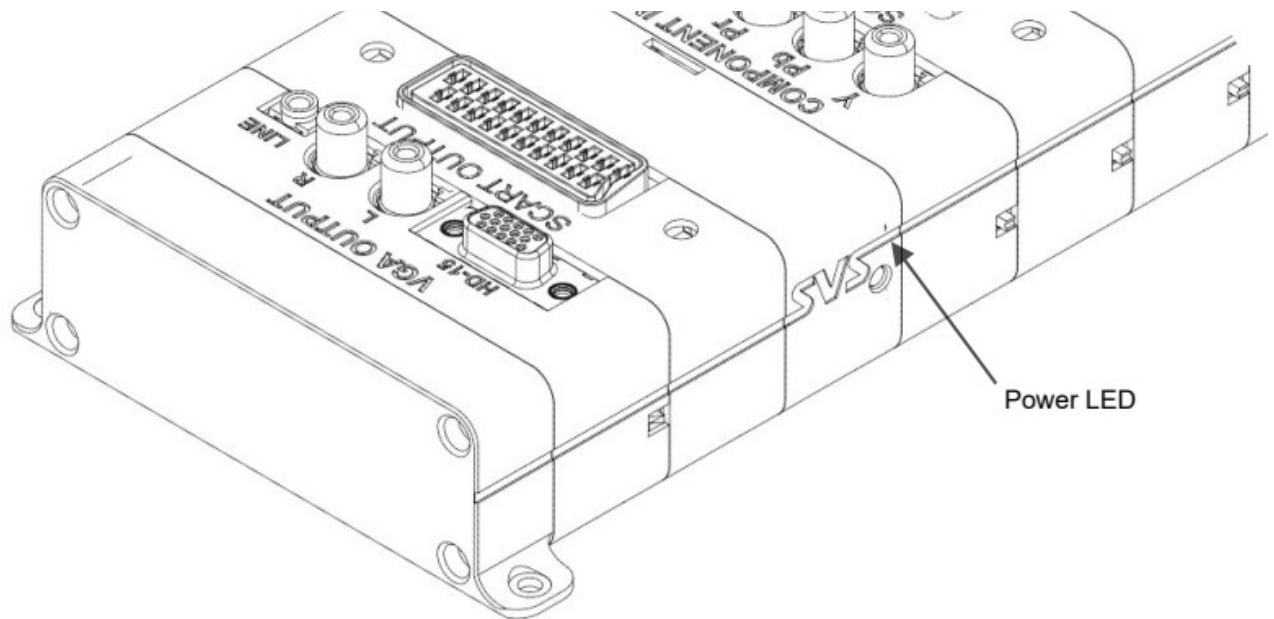

When you first boot your completed SVS build you will notice that the red power LED on the Control Module will be blinking. The blinking LED indicates that the Control Module has enumerated the input modules that are currently connected, and has determined that it needs to be factory reset to format the EEPROM addresses to match the current number of connected input modules.

To continue with the factory reset simply press the push button on the front of the Control Module. The red LED will go solid for a couple of seconds, then it will blink rapidly and turn off. At this point the factory reset is complete.

While the red LED is off, you have the opportunity to program IR codes for manually cycling inputs via IR remote. To program the IR code for “Input Up” simply point your remote at the Control Module and press the button on the remote that you would like to use for that function. A green LED will blink rapidly to indicate that your IR code has been read. Once you have programmed the code for cycle input forward, you should press the push button on the front of the Control Module. The red LED will blink once to indicate that the code has been saved.

Now you can program the code for “Input Down” by pressing the button on your remote that you would like to use for that function. A green LED will blink rapidly to indicate that your IR code has been read. Once you have programmed the code for cycle input backward, you should press the push button on the front of the Control Module. The red LED will turn on solid, which indicates that the IR setup is complete and the switch is now ready to use.

If you do not wish to set up IR codes you can skip these steps by simply pressing the push button twice in a row after the red LED turns off. That will simply not program any codes for those functions.

Normal Operation

Once the initial setup is complete the switch will function in auto detect mode. If an input signal is detected on any of the input modules the switch will automatically select the input that was detected. That input will remain selected until one of the following conditions occur.

1. If the input signal is no longer detected the input will be automatically deselected.
2. If an input signal is detected on one of the other inputs, the current input will be deselected and the newly detected input will be selected.
3. If the user manually cycles to a different input using either the pushbutton on the front of the Control Module, or using the “Input Up” or “Input Down” buttons on your IR Remote.

Manual Mode

Once the user manually cycles to an input the auto detection system changes behavior slightly. If an input is manually selected the auto detection system will no longer automatically cycle inputs when an active signal is no longer detected. Meaning that if you have manually cycled to an input, and you turn off the device that is connected to that input, the input will remain selected even though there is no longer a signal detected on that input. However if a new signal is detected on one of the other inputs, the switch will exit manual mode and auto detection will resume functioning as normal.

Infrared Remote Transmitter Programming

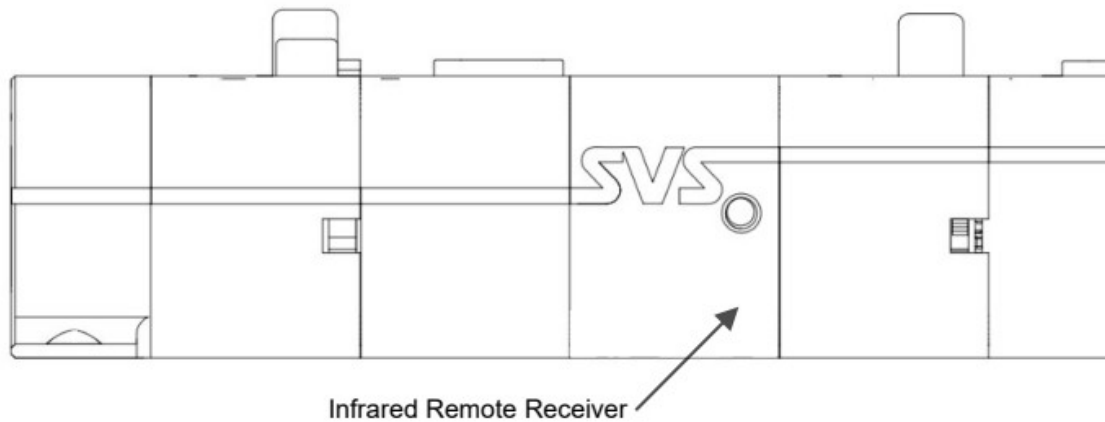

The Scalable Video Switch supports recording and playing back IR codes for each input. This feature is useful for automatically switching profile/input settings on your scaler when the switch detects a new input.

In order to program a code to one of your inputs, simply select the input you wish to program. You can select it by either manually cycling to it, or you can connect a video signal to that input to allow the auto detection system to select that input.

Once the input that you want to program is selected, simply press and hold the push button on the front of the Control Module for 3 seconds. The Red LED will turn off, then blink once indicating that you are in IR code programming mode.

At this point you can simply point your remote at the control module and press the button on your remote that you wish to program to current input. A green LED will flash on the Control Module to indicate that your code has been read.

If you wish to program an additional code that will be transmitted after your first code, you can do this by pressing the push button on the front of the Control Module. The red LED will blink twice to indicate that you have selected the second code slot for that input. Then you can simply press the button you would like to program on your remote and the green LED will blink to indicate that your code was read.

You may continue to follow this procedure to program however many codes you need for that input. The if you are not using an SD card the number of code slots that are available per input is determined by how many input modules you have connected. There are a total of 248 code slots available, so you can determine how many slots each input has available by dividing 248 by the number of inputs you have connected.

If you are using an SD card then there is no limit on how many code slots you can program per input.

Once you have programmed all of the IR codes you need for the current input, simply press and hold the push button on the front of the Control Module for 3 seconds. The red LED will turn on solid again, indicating that you have exited IR code programming mode. You can repeat this procedure on every input as needed.

Clearing IR Codes from an Input

To clear the codes that you have programmed to an input you can simply select the input you wish to program. You can select it by either manually cycling to it, or you can connect a video signal to that input to allow the auto detection system to select that input. Then press and hold the push button on the front of the Control Module for 10 seconds. The red LED will turn off, then blink rapidly to indicate that the IR codes have been cleared, then the red LED will turn on solid again.

Factory Reset

Factory reset will completely clear all settings and IR codes from the EEPROM or SD Card. There are 2 conditions that you can use to trigger a full factory reset.

1. If you add or remove input modules, the next time you power the switch on factory reset will be triggered and the red LED will quickly blink the number of times that corresponds to the previous number of inputs that were connected the last time the switch boots. To cancel the factory reset from this condition, simply unplug the switch, and restore the number of input modules to the previous configuration, then plug the switch back in. The factory reset will have been canceled and the switch will resume normal operation.
2. The second factory reset condition can be triggered by pressing and holding the push button on the front of the Control Module for 10 seconds while powering the switch on. The red LED will turn off, then flash rapidly to indicate the factory reset, then the red LED will turn off to indicate that it is ready to program the forward/backward IR codes as indicated in the “First Boot” section of this guide.

RetroTink 4k Integration

The Scalable Video Switch supports integration with the RetroTink 4k through the VGA Output module. If you connect the SVS to your RetroTink 4k using a VGA cable then your SVS will be able to control your RetroTink 4k's profiles automatically. In order for this feature work your RT4K needs to be updated to firmware version 1.6.9 or higher. You will need to enable the “AUTO LOAD SVS” option in the profile menu of your RT4K.

You will need to create a folder labeled “SVS” inside the “profile” folder of your RT4K's SD card. Then simply copy over the profile for each input that you want to auto load into that folder and then add “S#_” to the beginning of the filename where “#” is replaced with the input number that the profile should be assigned to. See examples below.

S1_PS2 DAR (Fill) NTSC 448, 960 - Sharp.rt4	1/1/2020 12:00 AM	RT4 File	23 KB
S2_Dreamcast RGBS PAR 480p & 480i DA...	1/1/2020 12:00 AM	RT4 File	23 KB
S3_PS1 DAR 10x.rt4	1/1/2020 12:00 AM	RT4 File	23 KB
S4_SNES DAR 10x.rt4	1/1/2020 12:00 AM	RT4 File	23 KB
S5_NES DAR 10x.rt4	1/1/2020 12:00 AM	RT4 File	23 KB
S6_SNES DAR 10x.rt4	1/1/2020 12:00 AM	RT4 File	23 KB
S7_N64 4-3 Fill.rt4	1/1/2020 12:00 AM	RT4 File	23 KB
S8_MD DAR 10x.rt4	1/1/2020 12:00 AM	RT4 File	23 KB
S9_Saturn PAR & Integer 320x & 704x - R...	1/1/2020 12:00 AM	RT4 File	23 KB

IR Remote Legend

